

产品规格承认书 SPECIFICATION

文件编号 File No.: UME-EG-SP25102401/A1

客户 Customer	AKON	核准 Approval	ZL
品名 Product	开关电源 Switching power supply	品管确认 QC	LTF
型号 Model	AD-AKB240P0400	审核 Check	ZL
日期 Date	2025-10-24	拟制 Execution	BMD

客户承认意见 Confirmation by Customer	客户签署 Stamp & Signature
<input type="checkbox"/> 合格 Accept	
<input type="checkbox"/> 不合格 Reject	
<input type="checkbox"/> 条件合格 Conditional Acceptance	

确认签署后，请回传一份。有任何问题，请尽快告知我们。

Please return one copy to us with your signature and feel free to contact us for any questions.

厦门友盟电子有限公司

XIAMEN UME ELECTRONICS CO., LTD.

电话 Tel:0592-2611448

地址：厦门市翔安区莲亭路火炬八方工业园10号楼882-7号8楼

Add: 8th Floor, No. 882-7, Lianting Road, Xiamen Torch Hi-Tech Zone (Xiangan) Industrial Zone

产品规格承认书 SPECIFICATION				文件编号 File No.	UME-EG-SP25102401/A1
品名 Product	开关电源 SPS	型号 Model	AD-AKB240P0400	日期 Date	2025-10-24

目录 INDEX

1	变更履历 Revision History	3
2	概述 Summary	4
3	技术要求 Technical requirements	4
3.1	安全标准 Safety Standards	4
3.2	Input	4
3.3	Output	4
3.4	可靠性及质量控制 Reliability and Quality Control	5
3.5	测试线路图 Test Circuit	9
4	线路图 Schematic Diagram	9
5	电路板图 P.C.B	10
6	CORD 图 (单位 unit: mm 颜色 color: Black)	11
7	AC CORD 图	7-12
7	外观示意图 Cord and Mechanical Drawing (单位 unit: mm 颜色 color: Black)	13
8	铭板标识 nameplate	14
9	包装方式 Packaging	14
10	材料清单 BOM	15

*** The products limited warranty period is 18 months.
(From date code of product.)**

● The products meet RoHS requirements.

批准 Approval:	ZL	审核 Check:	ZL	制表 Execution:	BMD
-----------------	----	-----------	----	---------------	-----

产品规格承认书				文件编号	UME-EG-SP25102401/A1
SPECIFICATION				File No.	
品名 Product	开关电源 SPS	型号 Model	AD-AKB240P0400	日期 Date	2025-10-24

2 概述 Summary

2.1 本文件包含一般的客户要求及电气、机构和安全性能等方面的描述。

This document contains general customer requirements and those of specific electrical, mechanical and safety for this product.

3 技术要求 Technical requirements

3.1 安全标准 Safety Standards

Japan: 電安法別表第八【JET6108-61010-1015A】

3.2 Input

Rated Input Voltage	100-240Vac
Operating Range	90-264Vac
Rated Input Frequency	50~60Hz
Rated Input Current	1.3A
Maximum Input Power	116W
Input Power (No Load)	0.21W Max
Primary Current Protection	Current fuse
AC Blade	PSE type AC Blade
AC Cable	<PS>E 2*0.75mm ² VCTFK L = 1800mm, Black, Lead-free soldering

3.3 Output

Rated output voltage	24V±5%
Rated Output Current	4000mA Max
Over Current Protection	4.4A Min @Vin=100Vac/240Vac
Line Regulation	The line regulation is less than ±2% while measuring at rated load and +/-5% of input voltage changing.
Ripple	≅ 200mVp-p
Switching Efficiency	88% minimum@ input 115AC/230VAC to meet DOE6
DC Plug	Φ2.1*5.5*9.5(EIAJ)
DC Cord	18AWG UL2464 L = 1000mm, Black, Lead-free soldering

批准 Approval:	ZL	审核 Check:	ZL	制表 Execution:	BMD
-----------------	----	-----------	----	---------------	-----

产品规格承认书 SPECIFICATION				文件编号 File No.	UME-EG-SP25102401/A1
品名 Product	开关电源 SPS	型号 Model	AD-AKB240P0400	日期 Date	2025-10-24

3.4 可靠性及质量控制 Reliability and Quality Control

【Electrical Test Items】

Item	Conditions	Criteria
1	Leakage Current Measure the leakage current between Primary and Secondary when adding rated input. AC input = Rating voltage (100/240V)	Less than 250μA
2	ESD Test 1. Test is conducted at room temperature/humidity.(25°C, RH 50-60%) 2. Test set is 150pF/150Ω. 3. (1)±4KV: Contact discharge test. +phase: 3times, -phase: 3times, total: 6times. (2)±8KV: Air discharge test. +phase: 3times, -phase: 3times, total: 6times. (Note) After each ESD test, it should be discharged.	No malfunction (must be in spec after test).
	1. Test is conducted at room temperature/humidity.(25°C, RH 50-60%) 2. Test set is 150pF/150Ω. 3. (1)±6KV: Contact discharge test. + phase: 3times, -phase: 3times total: 6times. (2)±10KV: Air discharge test. + phase: 3times, -phase: 3times, total: 6times. (Note) After each ESD test, it should be discharged.	No destruction
	ESD Test (Ability test) 1. Test is conducted at room temperature/humidity.(25°C, RH 50-60%) 2. Test condition: 150pF/150Ω. 3. Contact discharge / Air discharge 4. Load: 1)no load 2)rated load 5. Impressing 10 times continuously to plus and minus each. 6. Discharging once after impressing 10 times (To confirm the capacity of unit up to the unit destroyed)	It confirms at which voltage value the adapter breaks.(Note: Not part of qualification)
3	Hi-pot test Condition=AC3000V, 1min. Test place=Between AC blade and DC plug Sensitivity current=10mA	No malfunction. (damage, arc, breakdown etc)
4	Insulation resistance DC500V, 1min. Between AC blade and DC plug	More than 100MΩ
5	Temperature Rise Test 1. Apply rating input voltage(100/240V), 2. Load: Load meter with load 3. Measure the surface temperature of the adaptor 4. T ambient = The room temperature 5. Condition: Until it carries out temperature saturation (the definition of temperature than 1°C in 1 hour).	Housing surface Temperature rise is less than 65K.

批准 Approval:	ZL	审核 Check:	ZL	制表 Execution:	BMD
-----------------	----	-----------	----	---------------	-----

产品规格承认书 SPECIFICATION				文件编号 File No.	UME-EG-SP25102401/A1
品名 Product	开关电源 SPS	型号 Model	AD-AKB240P0400	日期 Date	2025-10-24

		1. Apply rating input voltage(100/240V), 2.No Load 3.Measure the surface temperature of the adaptor	Housing surface Temperature rise is less than 15K.
6	Input over / under	Apply voltage=(rating input voltage)x(1±30%) Impressed time : 24h	No destruction
7	EMI/Conducted Emission	Telephone stand by mode with rapid-charge condition	Conform to: FCC 47CFR Part 15 Class B (for US) EN55032
8	Surge	IEC61000-4-5 1.2×50µs 1.0KV Positive and negative all three times, Current limiting impedance 100 Ω, Time interval 30 seconds min.	No destruction.

【Environmental Test Items】

Item		Conditions	Criteria
1	Temperature range	Electrical performance guarantees temperature range: 0°C to 40°C、 Electrical performance not guarantees working temperature range: -20°C to 50°C Storage temperature range: -30°C to 80°C	No abnormal appearance, mechanic performance or electric performance
2	High Temperature Leave	1. Temperature 80°C for 96 hours. 2. After that test, test set is left in normal temperature, humidity condition for more than 1hour, then evaluate.	No abnormal appearance, mechanic performance or electric performance
3	Low Temperature Leave	1. Temperature -30°C for 96 hours. 2. After that test, test set is left in normal temperature, humidity condition more than 1(hour), then evaluate.	
4	High Temperature Humidity	1. Temperature 50°C, air moisture 90-95% RH for 96 hours. 2. After that test, test set is left in normal temperature, humidity condition more than 30min, then evaluate.	
5	Temperature Humidity test	1. Temperature 40°C, air moisture 90-95% RH for 96 hours. 2. After that test, test set is left in normal temperature, humidity condition more than 30min, then evaluate.	
6	Heat Shock Test	1. Condition: -30°C/ 1 hour to +80°C/ 1 hour, 60 cycles 2. After that test, test set is left in normal temperature, humidity condition more than 1 hour, then evaluate.	
7	Heat/humidity Cycle Test	A, C, D : RH=90 ± 10% B : RH= 90 ± 5% E : No limit After 5cycles, put EUT at room temperature/humidity condition	

批准 Approval:	ZL	审核 Check:	ZL	制表 Execution:	BMD
-----------------	----	-----------	----	---------------	-----

产品规格承认书 SPECIFICATION				文件编号 File No.	UME-EG-SP25102401/A1
品名 Product	开关电源 SPS	型号 Model	AD-AKB240P0400	日期 Date	2025-10-24

8	Humidity	Operation is 10~85%. Storages is 5~95%	Non-condensing

【Mechanical Test Items】

Item	Conditions	Criteria
1	Drop Test Height of drop: 1m, 1times/each surface (total 6 times), Floor: Hardwood.	No parts remove, no abnormal mechanic performance, (outside scratches are acceptable)
2	Package Drop Test 1. Packaged condition. 2. Drop test points (1) 1 corner (2) 2 edges (3) 4 surfaces, Total: 7times drop test. 3. Height of drop:50cm. Bottom surface drop test only apply 65cm.	
3	Unit Vibration Test 1. Vibration condition:33.3Hz/min. 20.6m/s ² 2. (1)Top/Bottom direction:4-hours (2)Right/Left direction:2-hours (3) Front/Back direction:2-hours	
4	Package Vibration 1.Vibration condition: 5-55-5Hz/2min. (1)Top/Bottom direction : 12.5(m/S ²)30(min) (2) Right/left direction : 7.5(m/S ²)15(min)*2	
5	AC Plug in/out Test (AC Blade part) 1. AC Plug in/out test more than 5000times 2.10(times/min). 1 time is in/out action.	
6	Exfoliate with cellophane tape and examine it Use Nichiban 18mm or 24mm width	A character do not disappear. Don't take the label off the main body
7	The reliability to face each other to come off the label ① - 40°C ② 80°C ③ 50°C 90% Each 96 hours ④ ③ After, it is a thermal shock examination of 96 cycles	less than 0.25mm after an environmental examination
8	No tally part step Difference of the pitch by height differences of the tally part between casts	

批准 Approval:	ZL	审核 Check:	ZL	制表 Execution:	BMD
-----------------	----	-----------	----	---------------	-----

产品规格承认书 SPECIFICATION				文件编号 File No.	UME-EG-SP25102401/A1
品名 Product	开关电源 SPS	型号 Model	AD-AKB240P0400	日期 Date	2025-10-24

【DC cord Test Items】

Item	Conditions	Criteria
1	DC Cord strength (adaptor side / plug side) 1. Test part : Between adaptor and DC cord 2. Pull a cord with 98N(10Kgf) force 3. Time: 1min.	No abnormality such as wire cut, bushing come off
2	DC Cord Bending Test (adaptor side / plug side) Weight = 4.9N(500g) Angle = +/-90° Cycles in every minute = 40times/min. Test cycles = 1000times Note: contrarotate 90°, and then rotate it clockwise with 180° (+90°~-90°) , and at last return to origin. (1 Cycle : 0° ⇒-90° ⇒0° ⇒+90° ⇒0°)	Operate properly.
3	PLUG PULLING TEST1: Apply a 29.4N (3kgf) static load on the strain relief of the plug device at 5-direction (Upper, lower, right, left, and push) for each 1 minute, The solder must not peel off from PCB, mechanical and electric characteristic shall be normal.	No abnormality such as cord cut, bushing comes off.

【Safety Test Items】

1	MTBF	Make a measurement condition, a calculation standard clear	More than 50,000 hours
2	Part materials	It is maintenance or the incombustibility of contact / part materials approaching it in an outer fence, the charge department of the electric part	same as UL94V-0; more than it
3	print board	Incombustibility	same as UL94V-0; more than it
4	No tally part step	Difference of the pitch by height differences of the tally part between casts	less than 0.25mm after an environmental examination

批准 Approval:	ZL	审核 Check:	ZL	制表 Execution:	BMD
-----------------	----	-----------	----	---------------	-----

产品规格承认书 SPECIFICATION				文件编号 File No.	UME-EG-SP25102401/A1
品名 Product	开关电源 SPS	型号 Model	AD-AKB240P0400	日期 Date	2025-10-24

3.5 测试线路图 Test Circuit

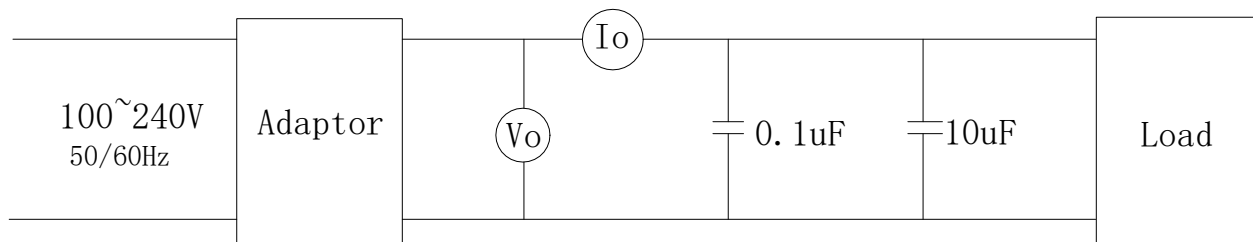

4 线路图 Schematic Diagram

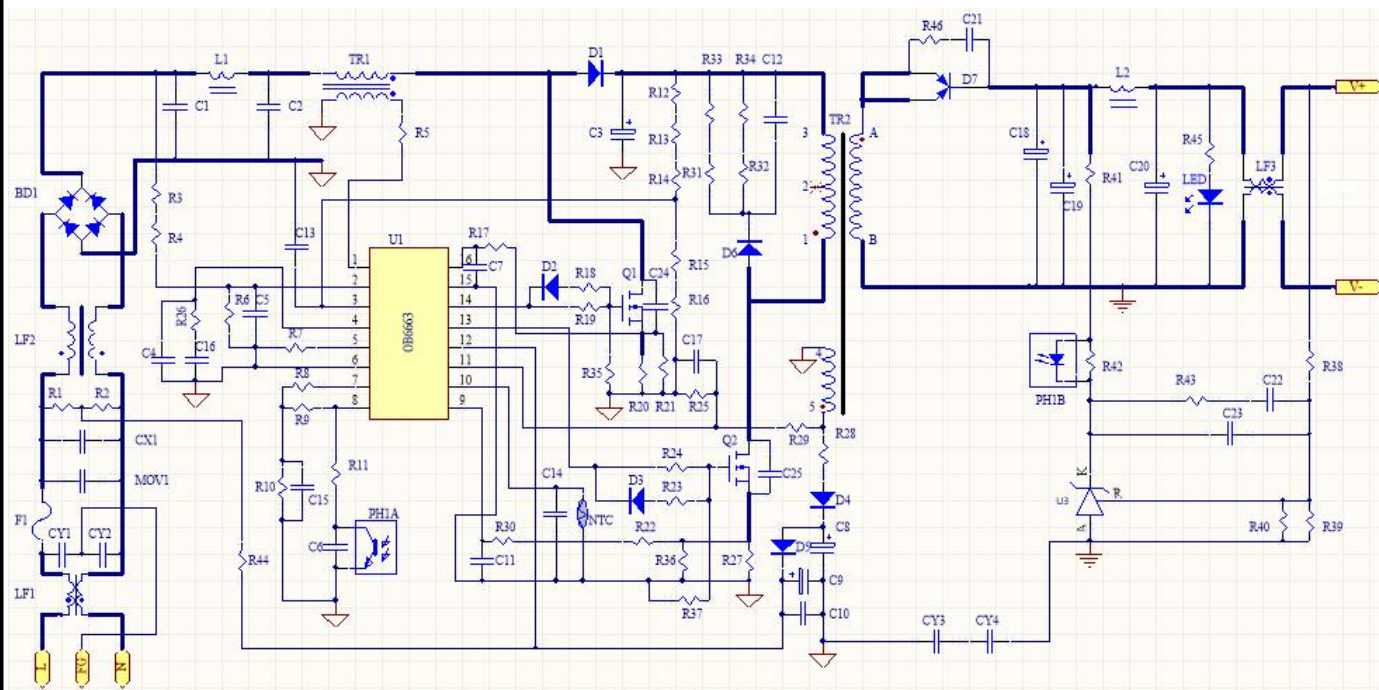

批准 Approval:	ZL	审核 Check:	ZL	制表 Execution:	BMD
-----------------	----	-----------	----	---------------	-----

产品规格承认书 SPECIFICATION				文件编号 File No.	UME-EG-SP25102401/A1
品名 Product	开关电源 SPS	型号 Model	AD-AKB240P0400	日期 Date	2025-10-24

5 电路板图 P.C.B

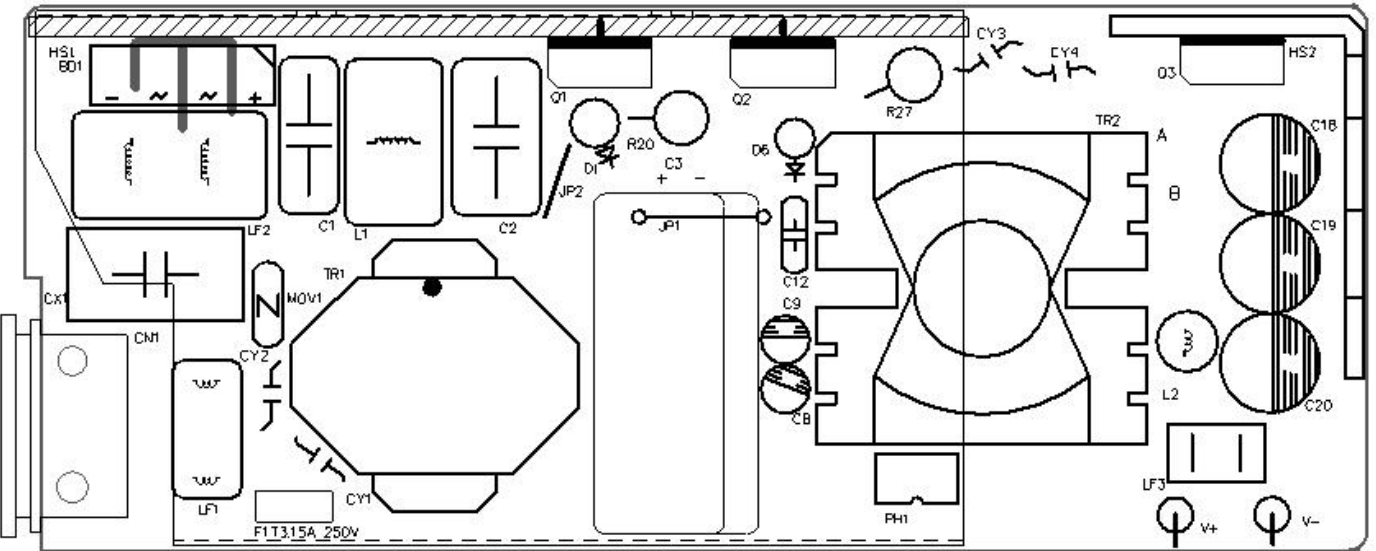
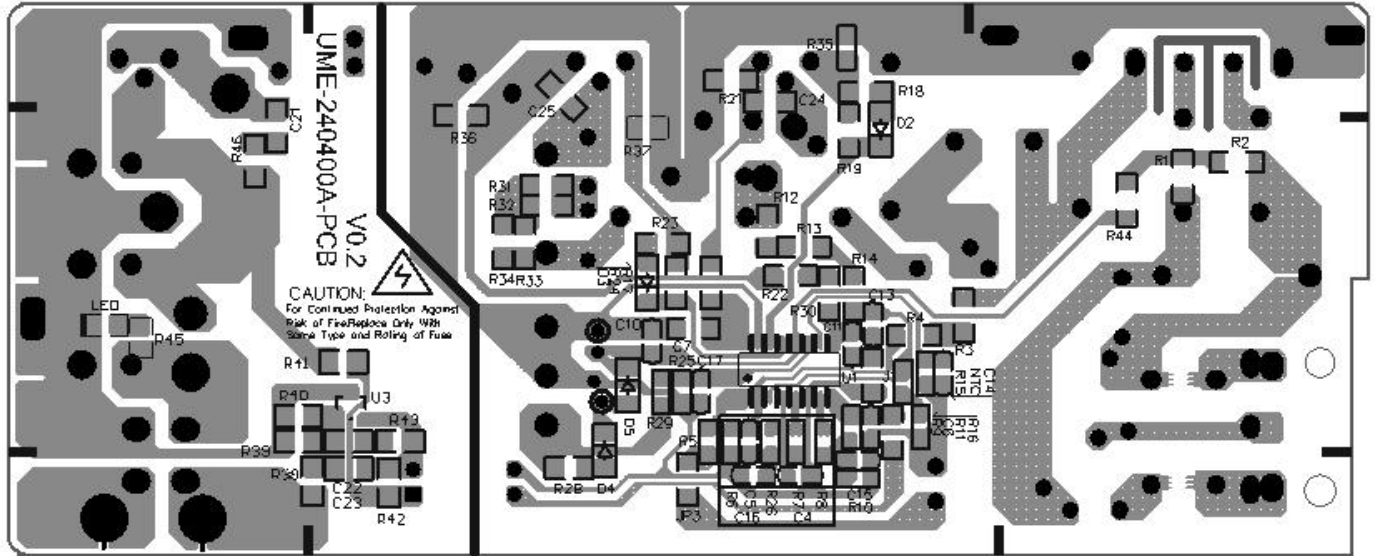

批准 Approval:	ZL	审核 Check:	ZL	制表 Execution:	BMD
-----------------	----	-----------	----	---------------	-----

产品规格承认书 SPECIFICATION				文件编号 File No.	UME-EG-SP25102401/A1
品名 Product	开关电源 SPS	型号 Model	AD-AKB240P0400	日期 Date	2025-10-24

6 CORD 图 (单位 unit: mm 颜色 color: Black)

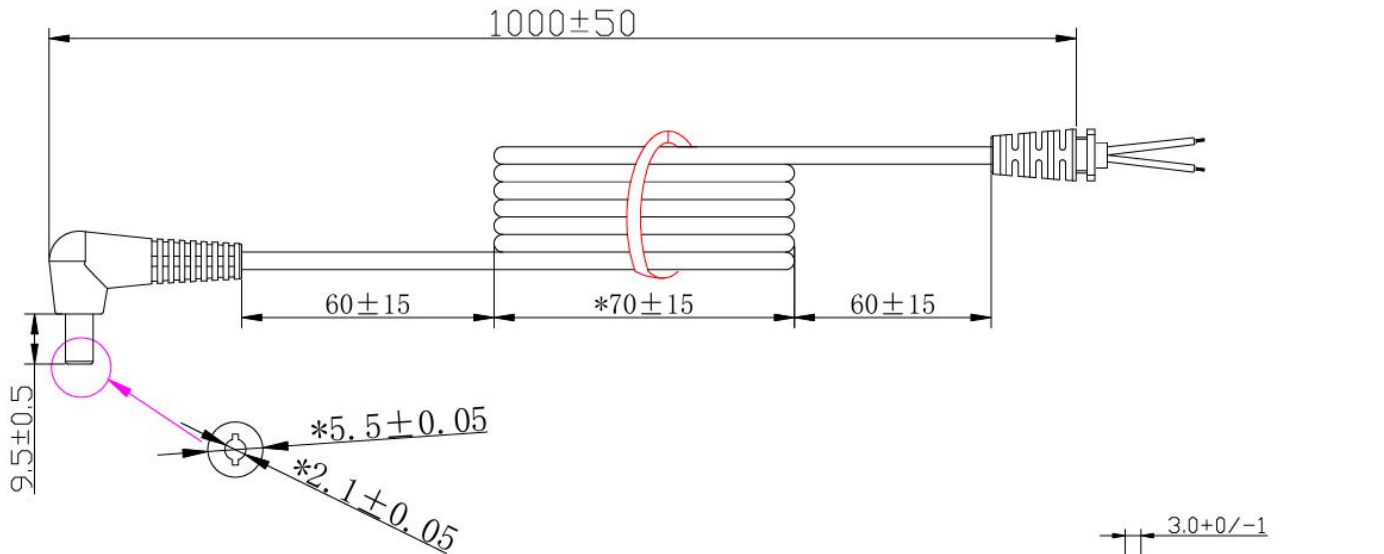

备注:

1. 导线规格: 18AWG 2464 音叉型 黑色, 芯线颜色: 红色+黑色, 导线总长 1000mm; 材质符合RoHS要求。导线按图示尺寸捆扎、测试, 导线间应开路, 对应线头线尾应短路导通, 极性连接正确;
2. 两头剥线焊锡, 剥线长度 $3\text{mm}+1/-0$ 。剥线要求如图所示, 剥线线焊锡的直径为 1.60mm MAX 。接线方式: 红色芯线接PIN中心, 黑色芯线接外侧, 外模PG-017头成型含内模INPG-007, SR017成型; SR017尺寸为 $9.0*8.0\text{mm}$ 。
3. SR拉力测试: 吊重 $1\text{Kg}/10$ 分钟, 不可有位移, 吊重 $5\text{Kg}/1$ 分钟, 位移 2mm MAX
4. 插拔力测试: 插入力 2Kg MAX , 拔出力 0.3Kg MIN ; 插拔 6000MIN 次不允许有电气和机械性能的损坏, 且满足拔出力 0.1Kg MIN ;
5. 摇摆测试: 吊重 500g , 以 40 次/分作 90° 往返, 每一往返为一次, 至少 1000 次;
6. PLUG绝缘阻抗测试: $100\Omega\text{ MIN}$ 在 500DC/分 ; PLUG接触阻抗测试: $100\text{m}\Omega\text{ MAX}$;
7. 导线, SR, PLUG非移行性依据厂内一般进行; 禁止使用VDE所禁用的物质。

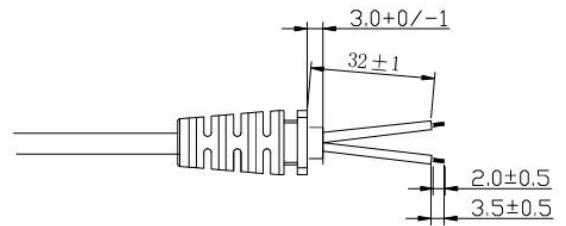

接线方式

DC头中心针 —— 红色芯线
DC外壳 —— 黑色芯线

批准 Approval:	ZL	审核 Check:	ZL	制表 Execution:	BMD
-----------------	----	-----------	----	---------------	-----

产品规格承认书 SPECIFICATION				文件编号 File No.	UME-EG-SP25102401/A1
品名 Product	开关电源 SPS	型号 Model	AD-AKB240P0400	日期 Date	2025-10-24

7 AC CORD 图

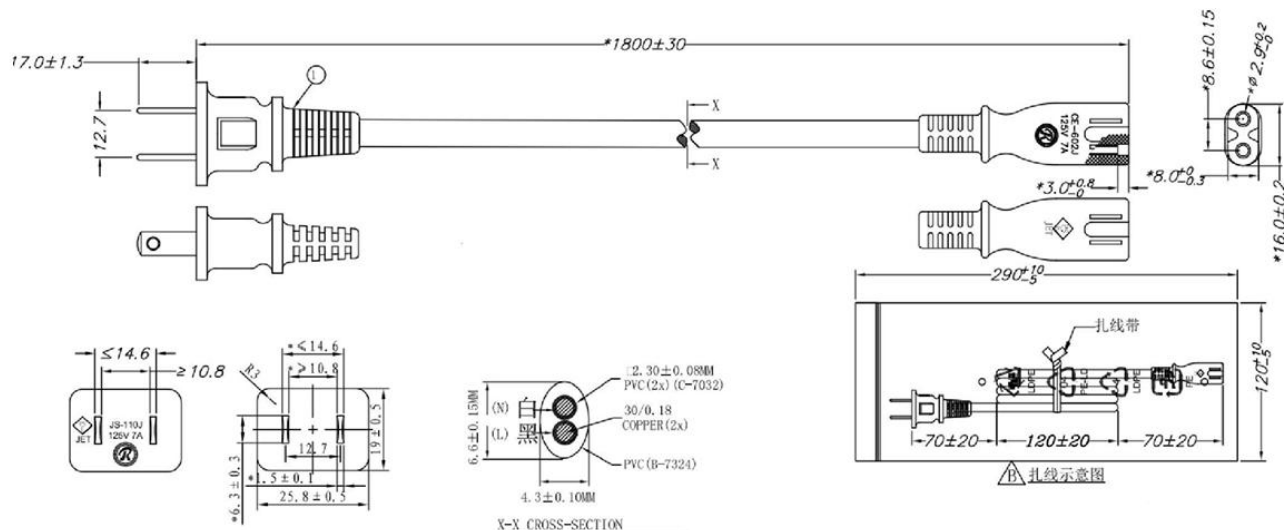

备注:

- 1、线材规格: VCTFK 0.75/2C BLK L:1800mm
- 2、导线按图示尺寸捆扎、测试。导线间应开路, 对应线头线尾应短路导通。
- 3、摇摆测试: 吊重500g, 以40次/分作60° 往返, 每一往返为一次, 至少5000次。
- 4、插头、线及接口符合PSE(日本)标准。
- 5、材质符合“RoHS”要求。
- 6、测试参数: 内高压3KV, 时间1S, 外高压4KV, 时间为2S, 绝缘 5MΩmin, 时间1S漏电流 0.5mA。
- 7、头部: JS-110J 尾部: CE-602J
- 8、插拔力: 10N-50N
- 9、印字内容: R31945 RoHS <PS>E JET6550-12009-1005 VCTFK
2*0.75mm² (30/0.18mm) 300V FUND RESOURCES ELECTRIC INDUSTRY CO., LTD SHANGHANG YEAR

批准 Approval:	ZL	审核 Check:	ZL	制表 Execution:	BMD
-----------------	----	-----------	----	---------------	-----

产品规格承认书 SPECIFICATION				文件编号 File No.	UME-EG-SP25102401/A1
品名 Product	开关电源 SPS	型号 Model	AD-AKB240P0400	日期 Date	2025-10-24

8 外观示意图 Cord and Mechanical Drawing (单位 unit: mm 颜色 color: Black)

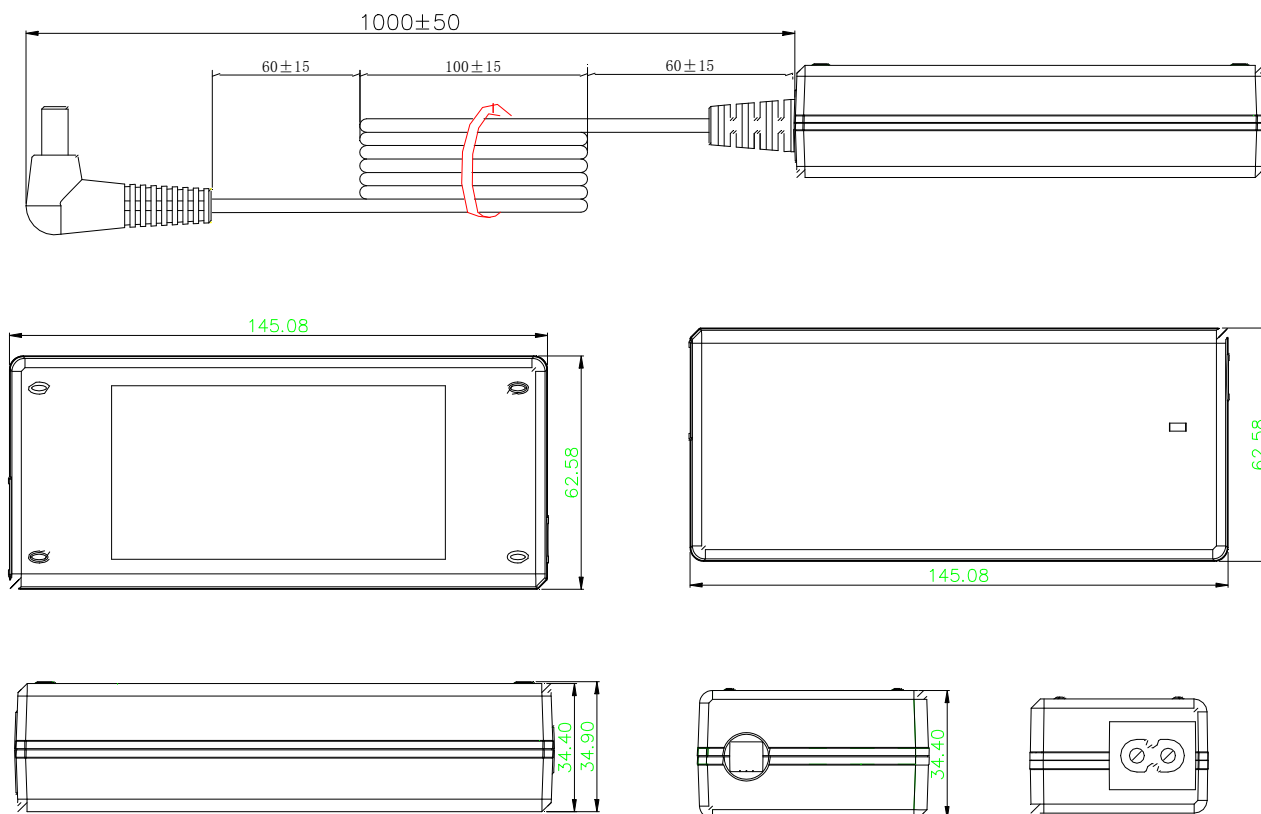

批准 Approval:	ZL	审核 Check:	ZL	制表 Execution:	BMD
-----------------	----	-----------	----	---------------	-----

产品规格承认书 SPECIFICATION				文件编号 File No.	UME-EG-SP25102401/A1
品名 Product	开关电源 SPS	型号 Model	AD-AKB240P0400	日期 Date	2025-10-24

9 铭板标识 nameplate

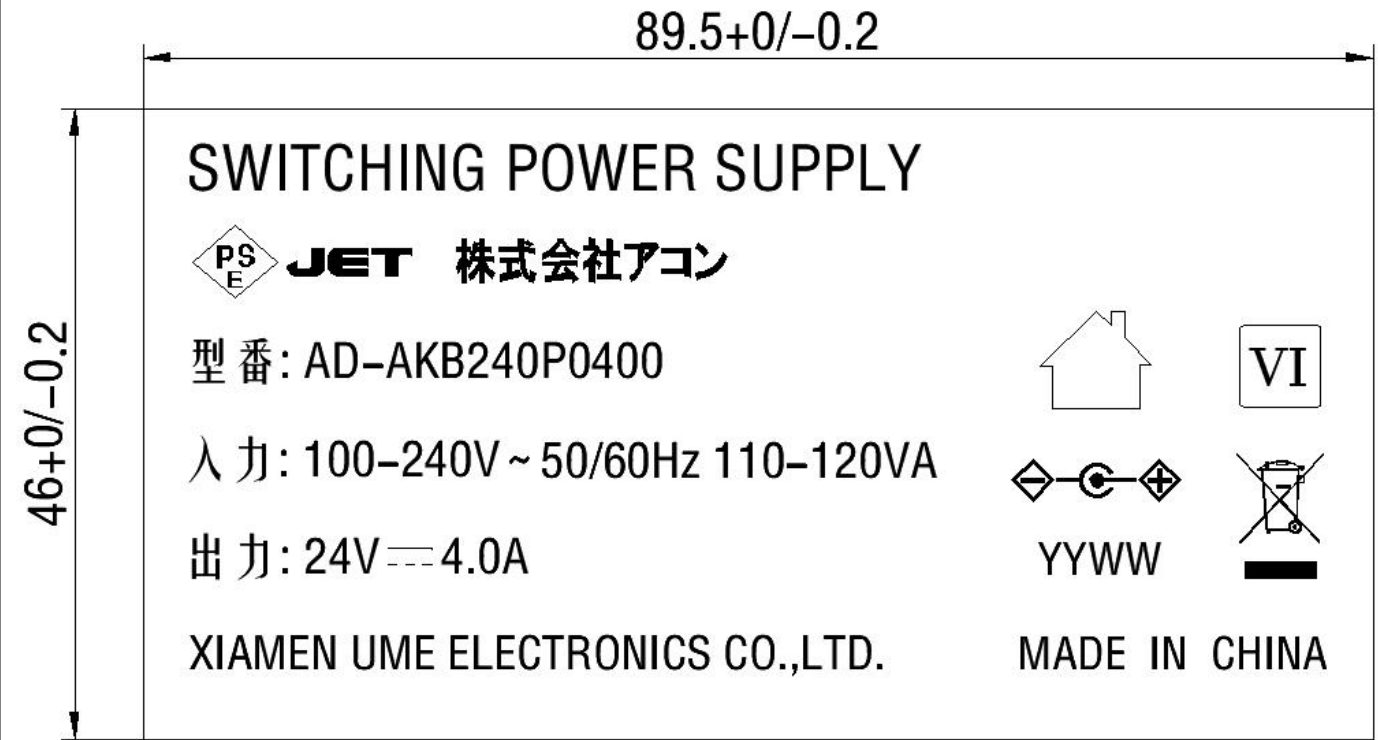

10 包装方式 Packaging

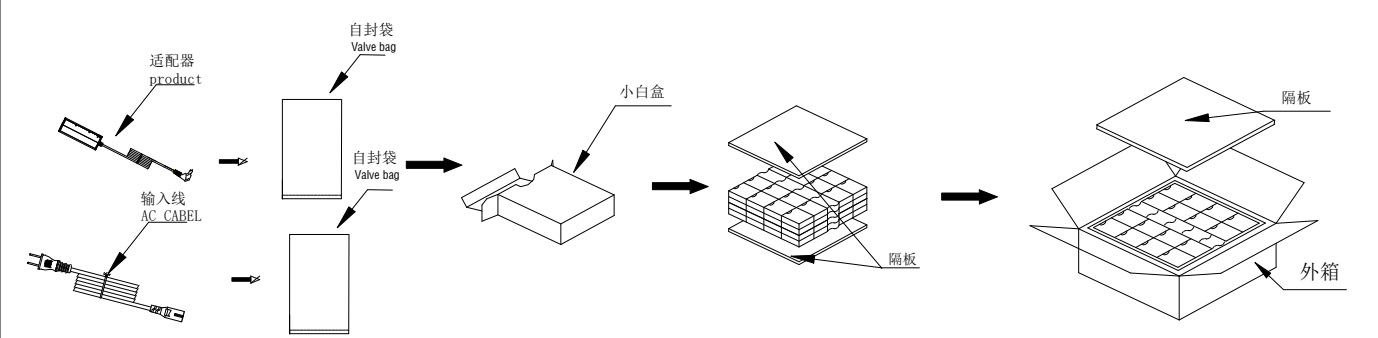

批准 Approval:	ZL	审核 Check:	ZL	制表 Execution:	BMD
-----------------	----	-----------	----	---------------	-----

产品规格承认书 SPECIFICATION				文件编号 File No.	UME-EG-SP25102401/A1
品名 Product	开关电源 SPS	型号 Model	AD-AKB240P0400	日期 Date	2025-10-24

11 材料清单 BOM

NO	ITEM	DESCRIPTION	SPECIFICATION	QTY	MANUFACTURER
1	PCB	PCB	UME-240400A-PCB	1	TXS/JT/MW/HG
2	R1,R2	Chip R	1M Ω ±5% 1206	2	YAGEO/FENG HUA
3	R3,R4,R12,R13,R14	Chip R	3.0M Ω ±5% 1206	5	YAGEO/FENG HUA
4	R5	Chip R	30K Ω ±5% 0805	1	YAGEO/FENG HUA
5	R6	Chip R	68K Ω ±5% 0805	1	YAGEO/FENG HUA
6	R7	Chip R	20K±5% 0805	1	YAGEO/FENG HUA
7	R11	Dip R	15 Ω ±5% 1206	1	YAGEO/FENG HUA
8	R15	Chip R	39K Ω ±1% 0805	1	YAGEO/FENG HUA
9	R16	Chip R	20K Ω ±1% 0805	1	YAGEO/FENG HUA
10	R17,R22	Chip R	510 Ω ±5% 1206	2	YAGEO/FENG HUA
11	R18	Chip R	10 Ω ±5% 1206	1	YAGEO/FENG HUA
12	R19	Chip R	30 Ω ±5% 1206	1	YAGEO/FENG HUA
13	R23	Chip R	47 Ω ±5% 1206	1	YAGEO/FENG HUA
14	R24	Chip R	100 Ω ±5% 1206	1	YAGEO/FENG HUA
15	R25,R45	Chip R	24K Ω ±5% 0805	2	YAGEO/FENG HUA
16	R26	Chip R	12K Ω ±5% 0805	1	YAGEO/FENG HUA
17	R28	Chip R	2 Ω ±1% 1206	1	YAGEO/FENG HUA
18	R29	Chip R	150K Ω ±5% 0805	1	YAGEO/FENG HUA
19	R30,J1	Chip R	0 Ω ±5% 1206	2	YAGEO/FENG HUA
20	R31,R32,R33,R34	Chip R	100K Ω ±5% 1206	4	YAGEO/FENG HUA
21	R35,R37	Chip R	10K Ω ±5% 0805	2	YAGEO/FENG HUA
22	R38	Chip R	91K Ω ±1% 0805	1	YAGEO/FENG HUA
23	R40	Chip R	10.5K Ω ±1% 0805	1	YAGEO/FENG HUA
24	R41,R43	Chip R	1K Ω ±5% 0805	2	YAGEO/FENG HUA
25	R42	Chip R	5.1K Ω ±5% 0805	1	YAGEO/FENG HUA
26	R44	Chip C	300K Ω ±5% 1206	1	YAGEO/FENG HUA

批准 Approval:	ZL	审核 Check:	ZL	制表 Execution:	BMD
-----------------	----	-----------	----	---------------	-----

产品规格承认书 SPECIFICATION				文件编号 File No.	UME-EG-SP25102401/A1
品名 Product	开关电源 SPS	型号 Model	AD-AKB240P0400	日期 Date	2025-10-24

27	R46	Chip C	22Ω±5% 1206	1	YAGEO/FENG HUA
28	JP3	Chip C	0Ω±5% 1206	1	YAGEO/FENG HUA
29	C4	Chip C	68nF±10% 50V 0805	1	YAGEO/FENG HUA
30	C5,C6	Chip C	472 50V±10% 0805 X7R	2	YAGEO/FENG HUA
31	C7	Chip C	471 50V±10% 1206 X7R	1	YAGEO/FENG HUA
32	C10	Chip C	104 50V±10% 0805 X7R	1	YAGEO/FENG HUA
33	C11,C13	Chip C	471 50V±10% 0805 X7R	2	YAGEO/FENG HUA
34	C16	Chip C	684 50V±10% 0805 X7R	1	YAGEO/FENG HUA
35	C17	Chip C	10PF 50V 0805 COG	1	YAGEO/FENG HUA
36	C21	Chip C	471 500V±10% 1206 X7R	1	YAGEO/FENG HUA
37	C22	Chip C	104 50V±10% 0805 X7R	1	YAGEO/FENG HUA
38	C23	Chip C	101 50V±10% 0805 X7R	1	YAGEO/FENG HUA
39	C24,C25	Chip C	101 1KV±5% 1206 X7R	2	YAGEO/FENG HUA
40	D2,D3,D5	Diode	1N4148W 75V 0.15A SOD-123	3	JF/MIC/PANJIT
41	D4	Diode	A7 1A/1000V/SOD-123	1	JF/MIC/PANJIT
42	LED	LED	0805 LED Green	1	Hong Qi
43	U1	IC	OB6663L SOP16	1	On Bright
44	U3	IC	CJ431±0.5% SOT-23	1	Changdian/UTC
45	D1	Diode	MUR460 4A 600V DO-201AD	1	JF/MIC/PANJIT
46	D1	D	Φ 1.15* 3.50*3mm	1	HXH
47	D6	Diode	RL207 2A 1000V DO-15	1	JF/MIC/PANJIT
48	C1	M Cap	474J400V P=15mm CBB21	1	STE
49	C2	M Cap	105J400V P=15mm CBB21	1	STE
50	MOV1	R	07D471±10%	1	STE
51	C3	E Cap	100uF 450V±20% 105℃ Φ 18*30mm(BXW)	1	RUBYCON
52		E Cap	100uF 450V±20% 105℃ Φ 18*35mm(TXW)		RUBYCON
53		E Cap	100uF 450V±20% 105℃ Φ 18*35.5mm(UCY)		NICHICON

批准 Approval:	ZL	审核 Check:	ZL	制表 Execution:	BMD
-----------------	----	-----------	----	---------------	-----

产品规格承认书 SPECIFICATION				文件编号 File No.	UME-EG-SP25102401/A1
品名 Product	开关电源 SPS	型号 Model	AD-AKB240P0400	日期 Date	2025-10-24

54	C8	E Cap	22uF 50V±20% 105℃ Φ5*11mm(YXF)	1	RUBYCON
55		E Cap	22uF 50V±20% 105℃ Φ5*11mm(YXG)		RUBYCON
56	C9	E Cap	4.7uF 50V±20% 105℃ Φ5*11mm(YXF)	1	RUBYCON
57	C18,C19,C20	E Cap	470uF 35V±20% 105℃ Φ10*20mm(ZLH)	3	RUBYCON
58	R20	R	0.27Ω 2W±5%	1	CS/HXH/ ZY
59	R27	R	0.22Ω 2W±1%	1	CS/HXH/ ZY
60	LF1	Inductance	2.0mH±20% φ 0.6mm (T18*10*7)	1	HXH/ZY
61	LF2	Inductance	20mH MIN φ0.5mm UEW+TLW	1	HXH/ZY
62	LF3	Inductance	280uH±20% φ 1.2mm (T13*7.5*5)	1	HXH/ZY
63	L1	Inductance	580uH MIN. Φ0.6 T18*10*6.5	1	HXH/ZY
64	L2	Inductance	1.2uH MIN.D4*18Φ1.2	1	HXH/ZY
65	CY1,CY2	Y cap	Y2 222 250V±20% P=7.5mm	2	STE/HJ
66	CY3,CY4	Y cap	Y2 472 250V±20% P=7.5mm	2	STE/HJ
67	CX1	X Cap	*0.33uF 250V±20% P=15mm	1	STE
68	TR1	TRANSFMOR	TR-120800A	1	HXH/UME/JQ
69	TR2	TRANSFMOR	TR-240400A	1	HXH/UME/JQ
70	FI	FUSE	*T3.15A/250V	1	XC
71		FUSE	*T3.15A/250V TSP		FYS
72	R20,R27	Tube	Φ5mm 125℃(UL)	18*2	Sanlian/WOER
73	BD1	Rectifier Bridge	KBL406G 600V 4A P=5mm	1	PANJIT/JF
74	Q1	MOSFEET	TK20A60W 600V 20A TO-220F	1	Magnachip/Toshiba
		MOSFEET	HF10N65 650V 10A TO-220F		HF/JF
75	Q2	MOSFEET	TK12A65D 650V 12A TO-220F	1	Magnachip/Toshiba
		MOSFEET	HF10N65 650V 10A TO-220F		HF/JF
76	D7	MOSFEET	SR30150CTH 150V 30A TO-220	1	GUANYU
77	L1,LF1,LF2	Silicon Sheet	10*18*3mm	3	GHT

批准 Approval:	ZL	审核 Check:	ZL	制表 Execution:	BMD
-----------------	----	-----------	----	---------------	-----

产品规格承认书 SPECIFICATION				文件编号 File No.	UME-EG-SP25102401/A1
品名 Product	开关电源 SPS	型号 Model	AD-AKB240P0400	日期 Date	2025-10-24

78	TR2	Silicon Sheet	45*55*1.5mm	1	GHT
79	Q1,Q2,D7	Screw	Φ3*8	3	Yunzhan/jixin
80	Q1,Q2,D7	Nut	Φ3mm	3	Yunzhan/jixin
81	D7	Insulation sheet	BUSHING T0-220	1	GHT
82	D7	Silicon Sheet	13*19*0.25mm	1	GHT
83	HS1	Heat Sink	SINK-120800T-1 (95*22*2.0)	1	XZ
84	HS2	Heat Sink	SINK-120800T-2 (24*22+43*22)*2.0	1	XZ
85	HS3	Heat Sink	SINK-120800T-3 (50*75*0.5)	1	XZ
86	PH1	Photo	EL-817MB DIP-4 P=10.2	1	Everlight
87		Photo	BPC-817MB DIP-4 P=10.2		Bright Led
88	JP1	Jump line	Φ0.5*21mm	1	UME
89	JP2	Jump line	Φ0.5*17mm	1	UME
90	CN1	AC INLET	ST-A03-005KT10(N)2.0	1	Chenli/BEJ
91		Case	UMED04-A BK	1	JLF/YGE
92		Case	UMED04-B BK	1	JLF/YGE
93		Light Pipe	4.52*2.01*2.5+Φ6*Φ4.52 d=9.04mm	1	JinTonZhou
94	NAP	NAP	NAP-240400A-PSE	1	Yihangxin /JinXin
95		DC cord	Φ2.1*5.5*9.5mm L:1000mm SR017 18AWG 2464	1	DPK/GC
96		AC Cable	<PS>E 2*0.75 mm ² VCTFK L=1800mm Black, Lead-free soldering	1	Kailiangao/JR
97		Valve bag	140*210*0.05mm	1	Xincheng
98		Valve bag	95*155*0.05mm	1	Xincheng
99		CARTON	350*345*280mm	0.025	XinRuicheng/ FuXing
100		LINER	345*340*3mm	0.05	XinRuicheng/ FuXing
101		BOOK	170*80*65mm	1	XinRuicheng/ FuXing
102		UL Bond	UB-100	0.55	U-BAN

批准 Approval:	ZL	审核 Check:	ZL	制表 Execution:	BMD
-----------------	----	-----------	----	---------------	-----

产品规格承认书 SPECIFICATION				文件编号 File No.	UME-EG-SP25102401/A1
品名 Product	开关电源 SPS	型号 Model	AD-AKB240P0400	日期 Date	2025-10-24

103		Solder Bar	Pb free	0.4	YUNNANXIYE
104		Solder wire	Pb free	0.2	YUNNANXIYE

批准 Approval:	ZL	审核 Check:	ZL	制表 Execution:	BMD
-----------------	----	-----------	----	---------------	-----